

EN

# USER MANUAL

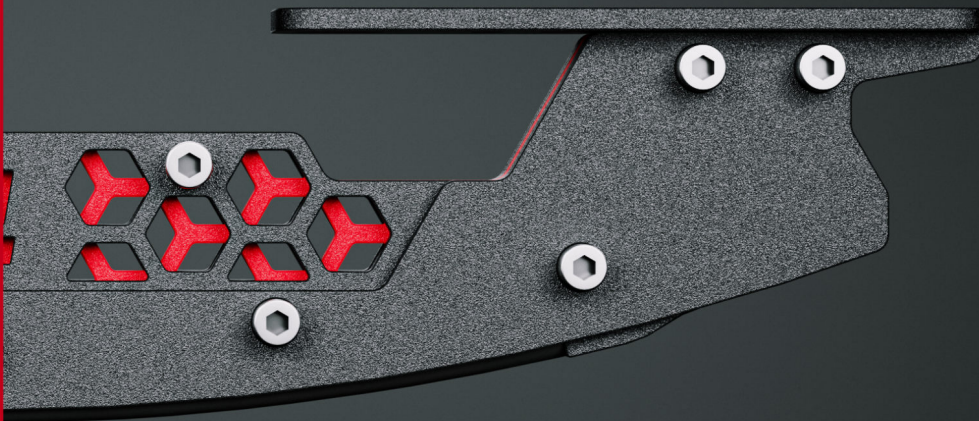

BORN TO  
PERFORM

**QS** PIVOT

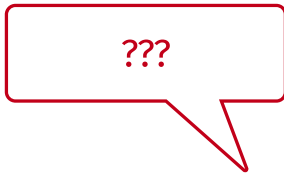

## ASK SUPPORT

Our experts are ready to assist you:  
[MotionSystems.eu/Support](https://MotionSystems.eu/Support)



## SEARCH OUR TUTORIALS

Everything you wish to know is here:  
[QubicSystem.com/Tutorials](https://QubicSystem.com/Tutorials)



## SUPPORTED GAMES

Racing games and professional simulation software:  
[QubicSystem.com/Supported-Games](https://QubicSystem.com/Supported-Games)

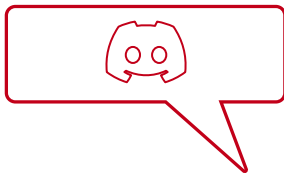

## DISCORD YOU ASK, WE ANSWER

Join our discord server to ask questions:  
[QubicSystem.com/Discord](https://QubicSystem.com/Discord)

# 1. QS-PIVOT

QS-Pivot bar enables you to run a 2DoF setup - two linear actuator on the back or on the front of the platform. It can be bolted to the bottom of the aluminum frame using included hardware. The adjustment range is presented in section 1.4 on page 5.

## INFO

QS-Pivot bar is an accessory purchased separately.

## 1.1. DIMENSIONS

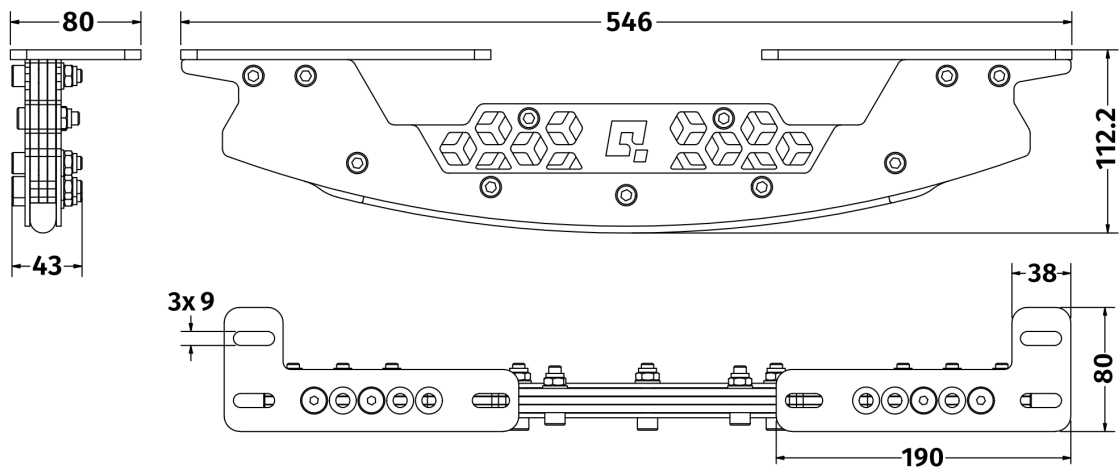

## 1.2. QS-PIVOT COMPONENTS

Included in the QS-Pivot box:

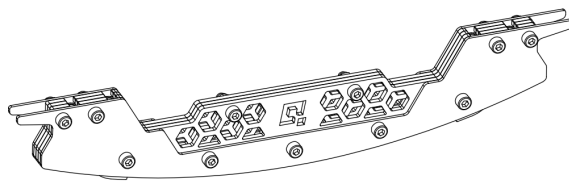

1 x  
Pivot bar

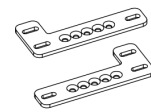

1 x  
Set of mounting  
plates



4 x

Bolt M8 x 20  
(DIN 7991)



2 x

Bolt M8 x 16  
(DIN 933)



4 x

Bolt M8 x 16  
(DIN 912)



6 x

T-Slot nut M8



4 x

Washer A 8,4  
(DIN 125)

### 1.3. MOUNTING TO AN ALUMINUM PROFILE COCKPIT

Use all of the included hardware to mount the QS-Pivot bar according to the pictures. QS-Pivot bar is to be installed to the underside of the aluminum profile. It can be installed either on the front or back of the cockpit - depending on your setup.

QS-Pivot bar can be moved closer to center of the rig to increase pitch movement **but** it **MUST** be installed to a crossbeam to increase stiffness. If there is no crossbeam in the preferred installation spot - it **MUST** be added.

1. Mount the installation plates to the QS-Pivot bar at a width that matches the cockpit. Mounting plates are not interchangeable because of countersunk holes - DIN 7991 bolts must sit flush inside them, when screwed in from the top.

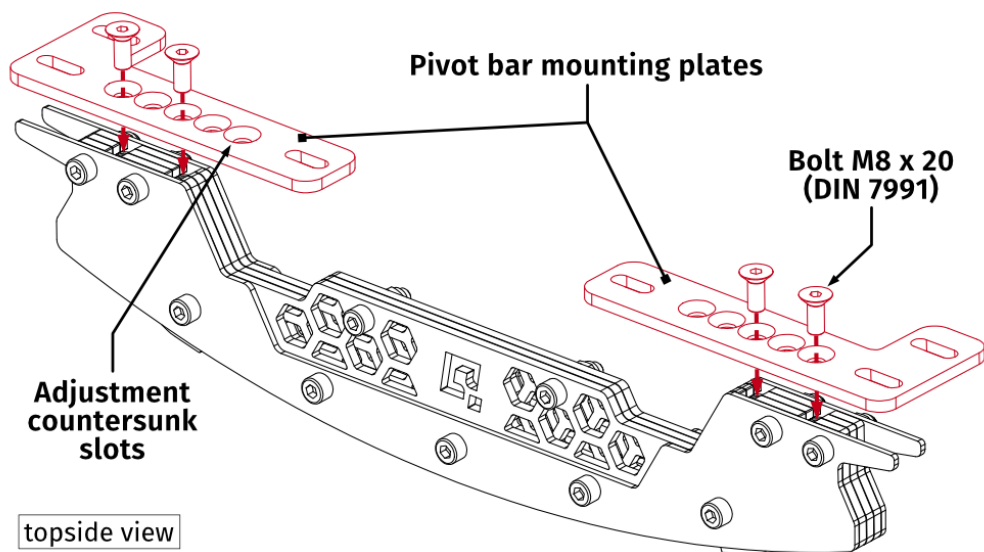

2. Screw the QS-Pivot bar in under the cockpit using included bolts.

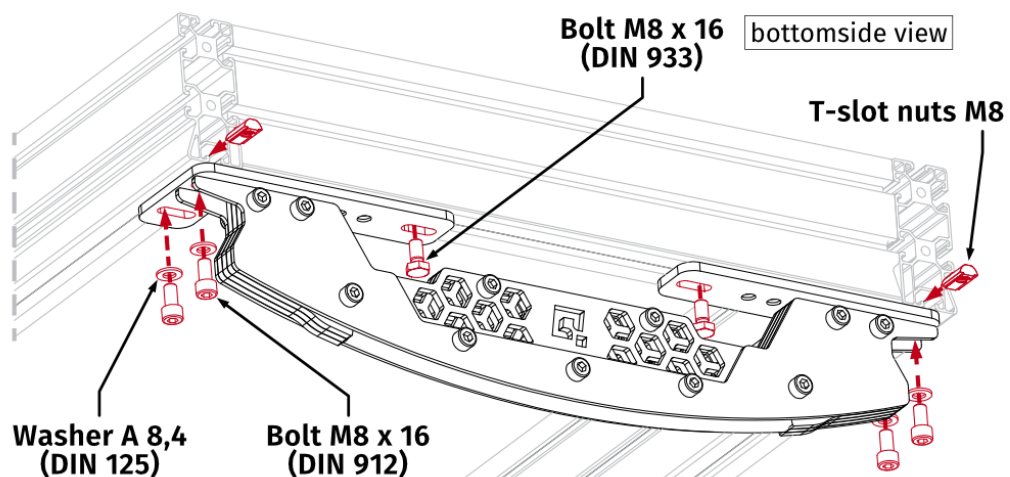

**INFO**

Use small amount of medium strength thread locker on all bolts.

---

## 1.4. ADJUSTMENT DIMENSIONS

For adjustment dimensions refer to the illustration below:

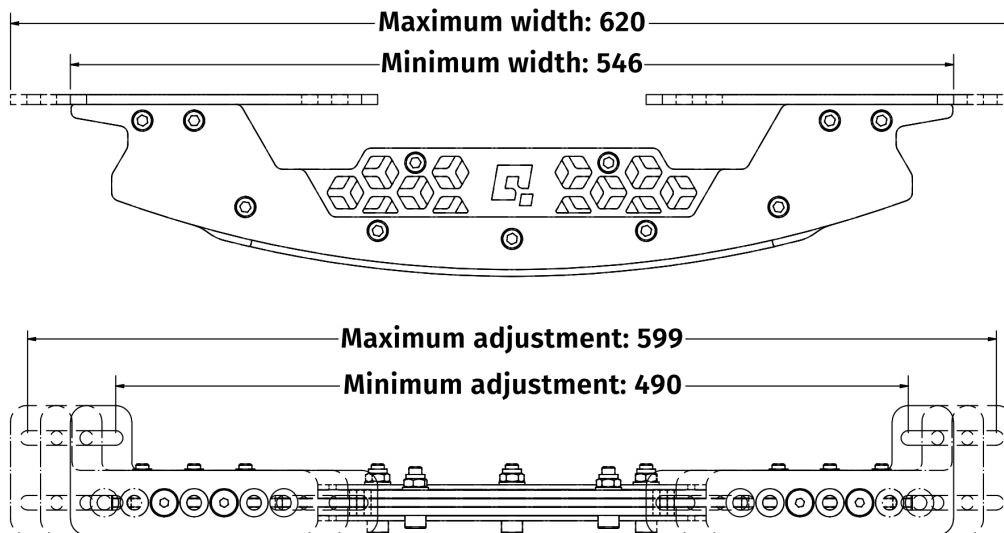

## 1.5. CORRECT INSTALLATION GUIDELINES

It is possible that incorrect installation of 2 front actuators + QS-Pivot at the back may cause undesired cockpit behavior — during dynamic weaving of a high-downforce/high-grip vehicle, the actuators may lose contact with the actuator feet (bounce off the ground).

Preventing actuator bouncing is crucial for user safety and for maintaining the durability of the motion platform's mechanical components.

What **hardware-related conditions** increase the possibility of actuators bouncing off the cups/feet?

- Actuators mounted too close together — excessive roll motion range resulting in a worsened side to side stability
- Racing seat mounted directly over the QS-Pivot and actuators mounted too far from the user — insufficient weight over the actuators
- Front actuators + rear QS-Pivot setup - for better stability, front QS-Pivot + back actuators setup is preferred

What **software-related conditions** increase the possibility of actuators bouncing off the cups/feet?

- Highly dynamic weaving in vehicles with significant downforce or grip capabilities (e.g., open-wheelers, single seater hyper- or sports-cars, GT racing cars)
- Ideal tire and track conditions resulting in maximum grip
- Direct-drive steering base set to maximum force feedback, reduced damping, and increased inertia — this may cause steering wheel oscillations at high speed
- High-speed crash with the Violent Movement Suppressor effect disabled in Qubic-Manager software

What steps must be taken to **minimize the risk** of actuator bouncing off the cups?

- **DO NOT** mount the actuators too close to each other — mount them on the side beams of the cockpit, not at the front
- Consider using included flat face profile mounting adapters to space out the actuators. Go to QS-210/QS-220 user manual.
- In high downforce/grip vehicle scenarios — reduce the Overall Gain slider value or decrease the Lateral G-force and Side Slip effects gains
- **NEVER** disable the Violent Movement Suppressor effect in the SFX tab by decreasing its sliders
- **DO NOT** mount the seat directly over or behind the QS-Pivot — this will not only reduce the risk of actuator bouncing but also improve the overall motion sensation for the user

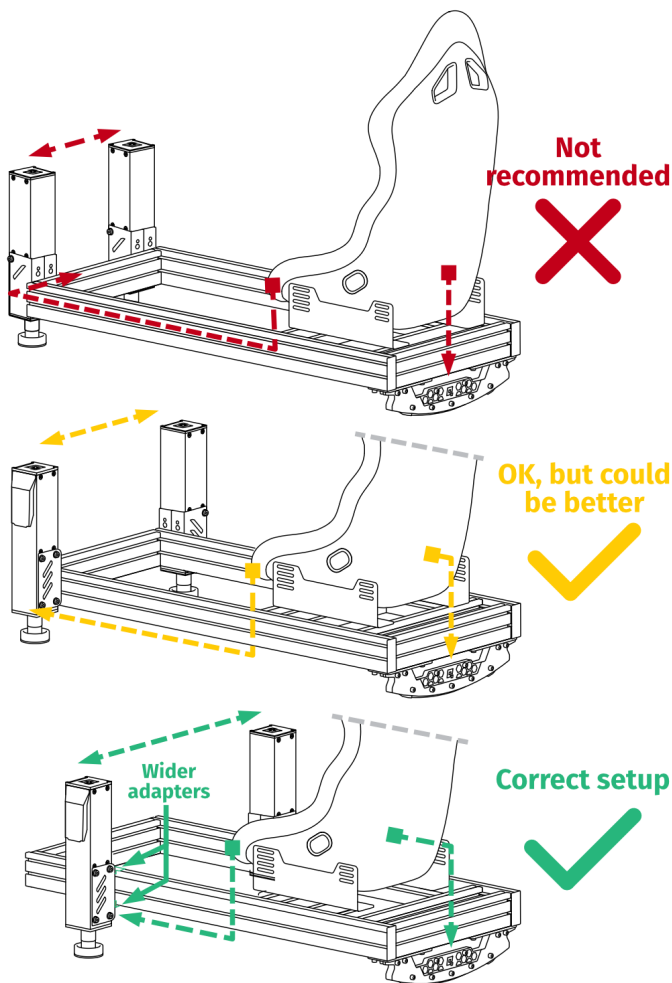

- Seat directly over the QS-Pivot - unwanted inertia
- Actuators in front - underloaded
- Too close to each other - too much roll for safe operation

- Seat moved forward - corrected weight balance
- Widened actuators mounting - more stable
- Too far away from user - underloaded

- Seat moved away from QS-Pivot - improved weight balance
- Actuators closer to user - more heavily loaded
- Added wider adapters for stabilization - info in QS-210/QS-220 user manual.

**WARNING**

Keep in mind that motion platform **implementations** using QS-220 actuators and QS-Pivot rely on the user's ingenuity and common sense. The QS-220 is capable of highly dynamic movements based on telemetry input from the simulator, and the motion rig must therefore be built to a safe specification with that in mind. Please exercise caution when installing and using this motion set.

 QUBICSYSTEM

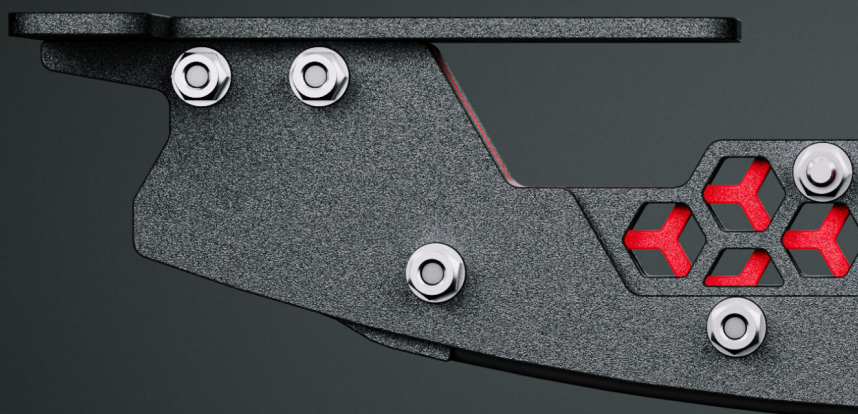

**Q5** PIVOT